

Adding Openness to Physics Education

Focusing on the Experiment of Newton's Second Law

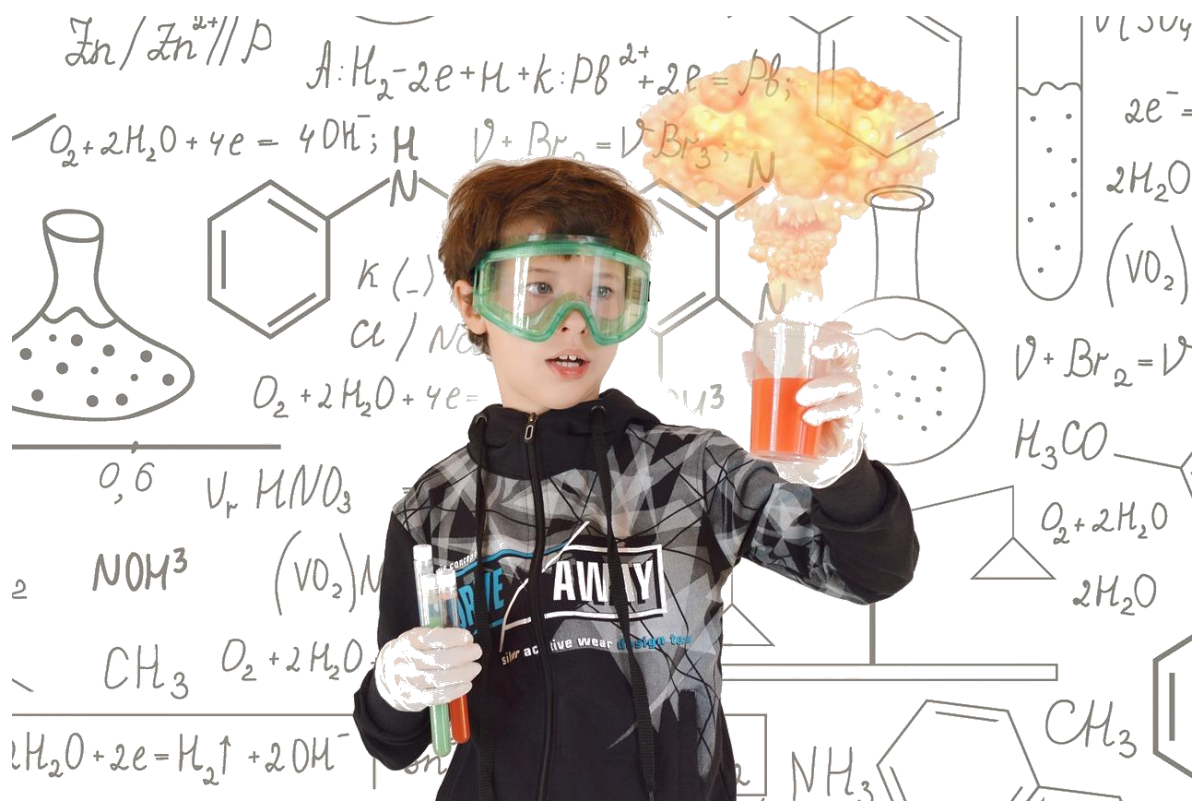

Sangwoo Ha

Kyungpook National University, Deagu, South Korea



Identity



- ✓ 2007-2011 : **Physics teacher**, High-schools of Gyeonggi province
- ✓ 2012-2020 : **Physics teacher**, Gyeonggi Science High-school for the Gifted
- ✓ 2020.09-present : Associate Professor, Kyungpook National University

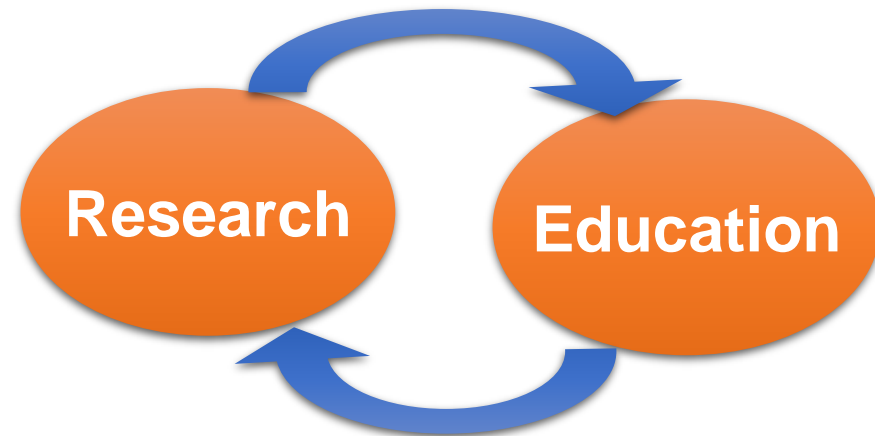

Identity

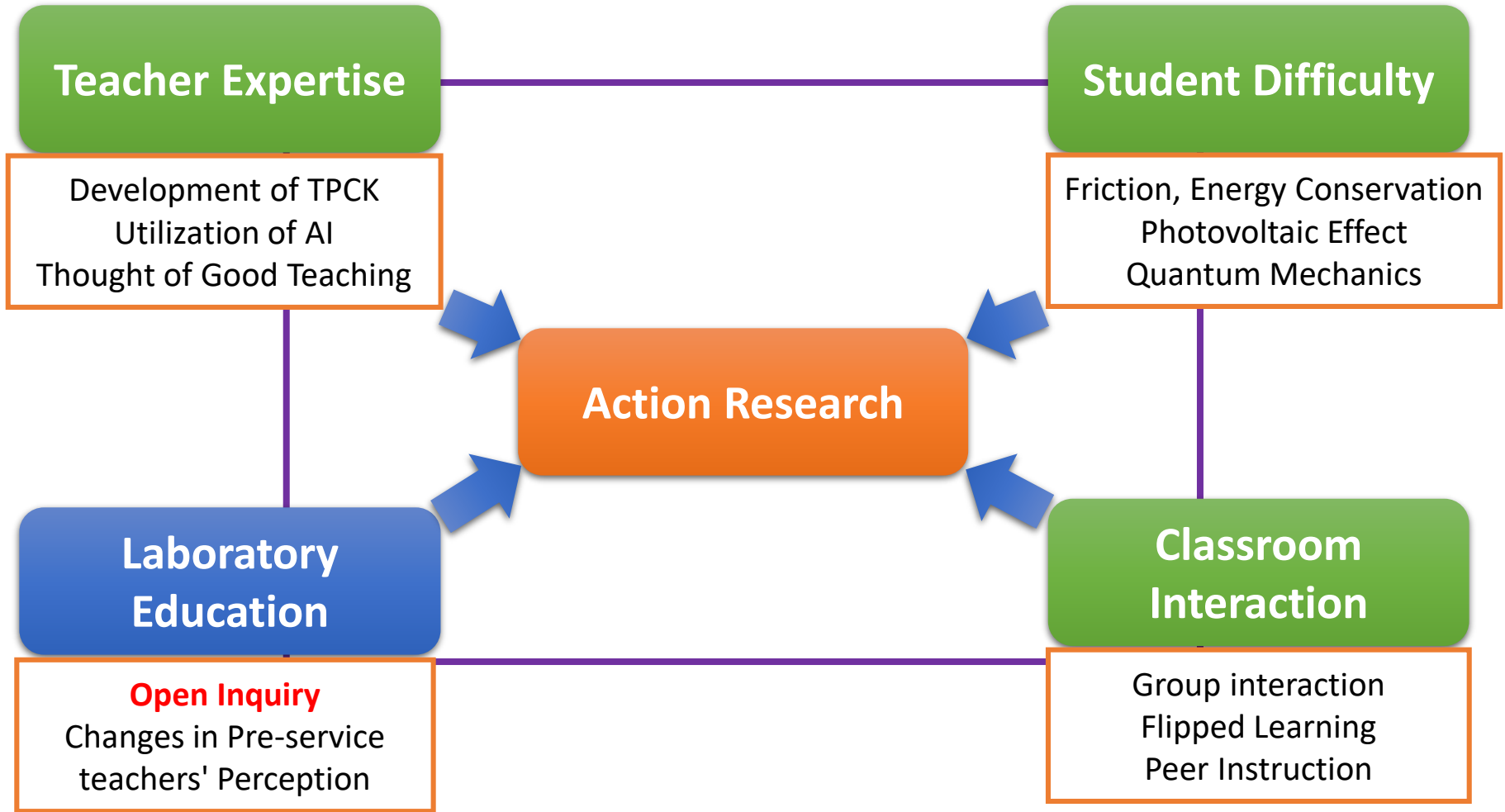

Researches to improve laboratory education

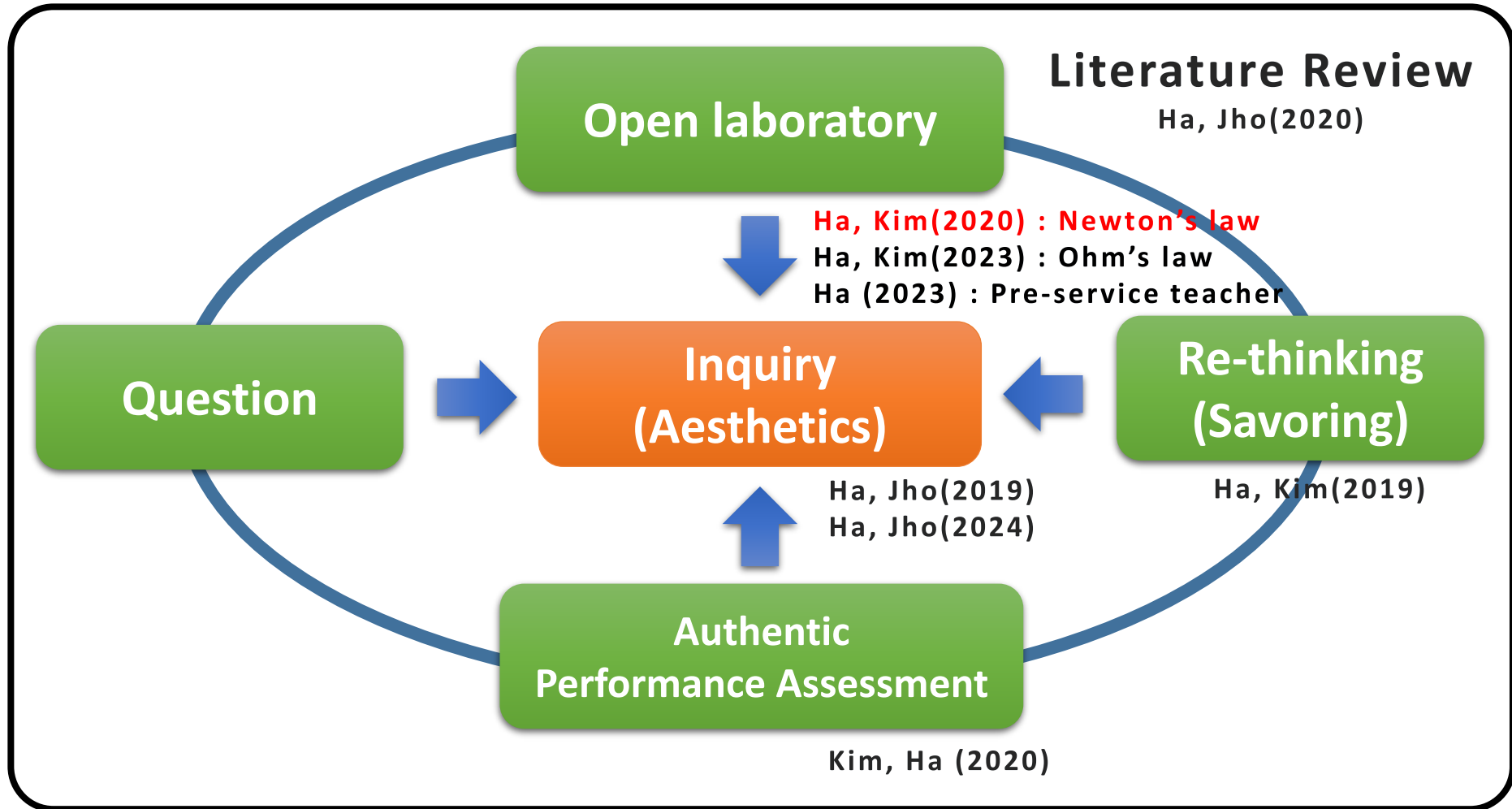

Difficulty of Newton's law

- ✓ Although Newton's second law is at the core of classical mechanics and it looks like a simple formula, many students have difficulty obtaining the exact meaning of the law and struggle to understand it (Thornton and Sokoloff, 1998; Hestenes et al., 1992).
- ✓ Students have little understanding of kinematics, Newton's laws of motion, and principles of superposition (Hestenes et al., 1992).
- ✓ They often demonstrate partially correct responses (not a full understanding) in that area (Thornton and Sokoloff, 1998).

Newton's law as Experiment

- ✓ Research has been conducted to provide students with concrete experience regarding Newton's second law because it was thought that students' difficulties were caused by the abstraction of the law (Lemmer, 2018).
- ✓ The application of teaching methods based on MBL (Microcomputer Based Laboratory) experiments have been shown to improve students' understanding of Newton's second law compared to traditional teaching methods (Thornton and Sokoloff, 1998).
- ✓ These studies insist that hands-on activities help students connect epistemological fragments and obtain conceptual understanding about Newton's law (Gates, 2014)

Positive Effects of Laboratory activities

- ✓ Laboratory activities appeal as a way of allowing students to learn with understanding and, at the same time, engage in the process of constructing knowledge by doing science (Tobin, 1990).
- ✓ Hand manipulation experiences help students understand theoretical concepts (Nissani et al., 1994).
- ✓ Encouraging students to think from data generally has a positive impact on student learning (Minner et al., 2010).
- ✓ Science educators generally expect that students' scientific abilities would improve with participation in laboratory activities (Gates, 2014)

Negative Effects of Laboratory activities

- ✓ There also exist many studies that insist laboratory activities do not help students' learning or understanding about science (Jerrim et al., 2019; Lazarowitz and Tamir, 1994; Tobin and Gallagher, 1987)
- ✓ Hodson (1998) reported that lab activity negatively affects students' understanding of the nature of science.
- ✓ Watson et al. (2004) found that the level of students' debate during laboratory activity was low, both quantitatively and qualitatively. Students were found to simply accept the results of the experiment as a conclusion and did not try to justify their argument (Watson et al., 2004).

Classification of laboratory activities

- ✓ Herron (1971) suggested four levels of inquiry through criteria based on the activity's problems, experimental methods, and whether or not an answer is given.
- ✓ Banchi and Bell (2008) divided inquiry type into that of confirmation, structured, guided, and open type according to the quantity of information provided and guidance given to students.
- ✓ Yang et al.'s (2006) literature review found that laboratory activities are often classified according to criteria about the degree of openness, the purpose of experimental classes, learning results, and the subjects of the experimental classes.
- ✓ Among the classification of the laboratory activity, the degree of openness was one of the most significant criteria that positively influenced students' learning (Staer, et al., 1998).

Current Situation in Korea

- ✓ Most textbook experiments in Korea are verification experiments intended solely to help with the learning of facts and concepts (Kim and Song, 2003; Lee and Choi, 2018).
- ✓ Many teachers in Korea want to lead students to follow a fixed experimental process.
- ✓ It could be a great difficulty for teachers to prepare various experimental devices and materials due to excessive work and the risk of safety accidents (Park, 2013; Lee & Lee, 2018).



Solution

- ✓ Many studies have emphasized the need for open inquiry. (Etkina et al., 2010; Szott, 2014; Staer, et al., 1998)



- ✓ However, teachers do not know how to make open laboratory classrooms, and there is a gap between the perception of need for open inquiry and the reality of conducting desirable classes (Paeng and Paik, 2015).
- ✓ There are many obstacles in the conducting of open laboratories in the classroom.
- ✓ Is there any way to change the class with less effort?

Partially Open Inquiry

- ✓ Herron (1971) suggested four levels of inquiry through criteria based on the activity's problems, experimental methods, and whether or not an answer is given.

Four levels of inquiry (Herron, 1971)

Level of Inquiry	Problems	Ways & Means	Answers
Level 0	Given	Given	Given
Level 1	Given	Given	Open
Level 2	Given	Open	Open
Level 3	Open	Open	Open
<u>Partially</u>	Given	<u>Open</u>	Given

Partially Open Inquiry

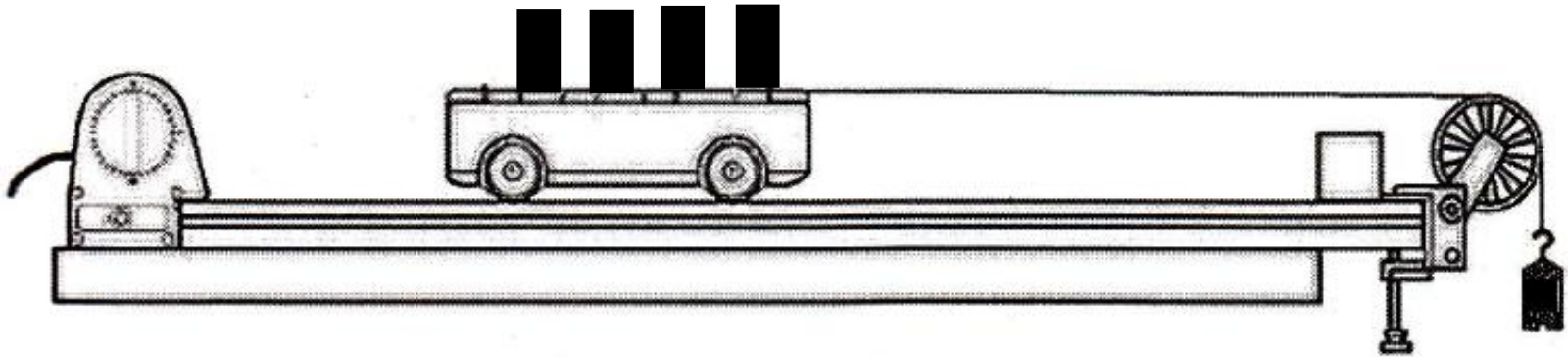

- ✓ Students follow the Newton's Second Law experiment as presented by the teacher at first.
- ✓ To maintain the mass of the system constant, we let the students initially loaded weights onto the cart and conducted the experiment by utilizing the weights on the cart to accelerate the system.
- ✓ However, even with precise experimentation by the teacher, an error rate of approximately 10% occurred on this experiment.

Partially Open Inquiry

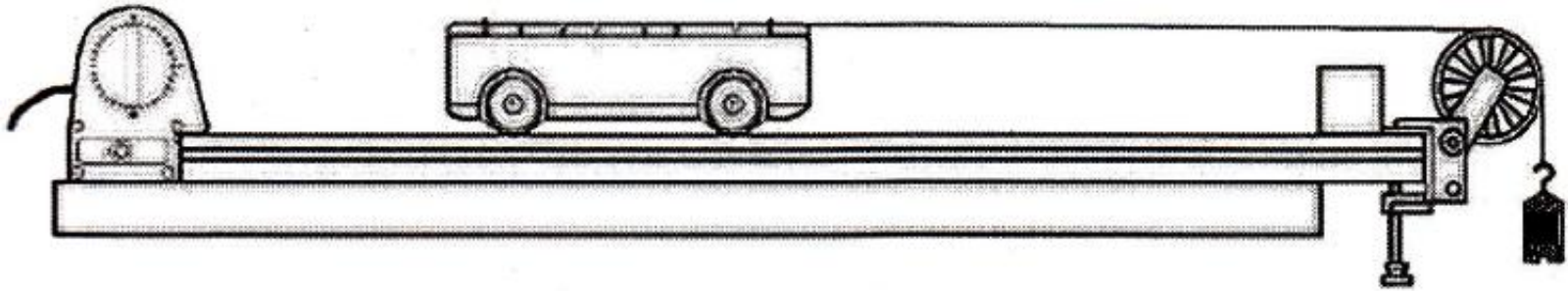

Mass of weight[g]	Average acceleration	Theoretical acceleration	Percentage Error [%]
9.8	0.136	0.174	21.8
20.2	0.317	0.359	11.7
30.1	0.493	0.535	7.9
40.4	0.670	0.719	6.8
50.2	0.844	0.893	5.5

- ✓ It can be inferred that the frictional force acting on the cart is a major factor contributing to the increase in error rate as the mass of the weights decreases.
- ✓ Therefore, we instructed students to consider (measure) the frictional force acting on the cart in order to derive the experimental results.

Partially Open Inquiry

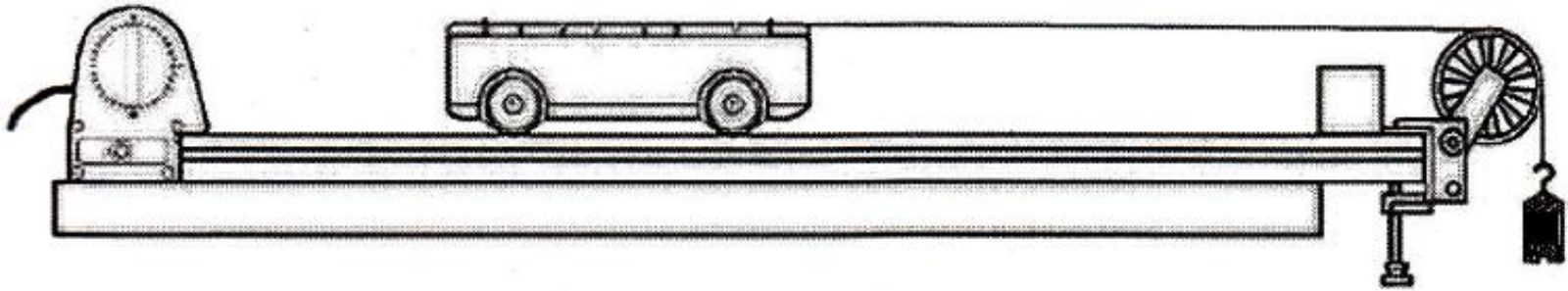

- ✓ Despite considering various factors including friction of the cart, students still experienced an error rate of approximately 10% in their experiments.
- ✓ We encouraged students to repeat the experiment with their own creative methods to minimize errors in Newton's second law experiments.

Problems	Given : Despite conducting the experiment with MBL, why is there such a significant error rate?
Ways & Means	Open : What is an excellent method to verify Newton's Second Law by experiment?
Answers	Given : Discover the proportional relationship between force and acceleration.

Research Context

- ✓ 110 science gifted school students, 7 classrooms, 28 groups

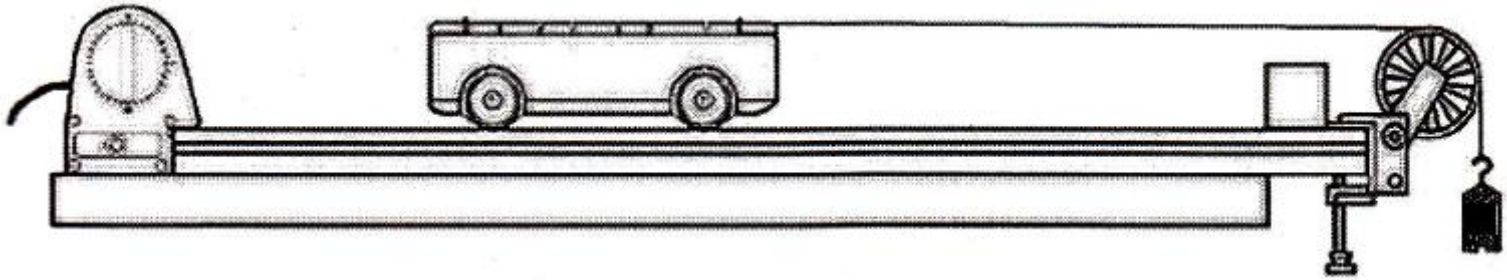

- ✓ Suppose that you are a university professor and teach general physics experiments. If you have a Newton's second law experiment in your curriculum and want to deal with it, what experiment design will you use?
- ✓ Newton did not find the relationship between force and acceleration through this experiment, but should we deal with this experiment?
- ✓ What do students learn from this experiment?

Research Method

Conduct the experiments in groups as suggested by the teacher



Two weeks later

Students conduct the experiment from their design



One week later

Present the results of the experiment



Peer evaluation of other groups' inquiry



Write opinions about this activity and other group's inquiry



After the course

Write opinions about this activity

Research Method

- ✓ Questionnaire immediately after the activity
 1. Describe what you have learned and felt from the three-week deep exploration experiment with the theme of $F = ma$.
 2. $F = ma$ is a typical experiment where the methods employed by scientists in conducting research differ from the approaches students take in learning. Describe your opinions on these experiments.
 3. Write down the pros and cons of each group's presentation, choose which groups presentation is the most impressive and describe the reason.

- ✓ Questionnaire of final term
 4. Newton's law experiments were conducted in the way the teacher guided them, then repeated and presented one more time in the way you wanted. Describe your opinions about how you think about this type of teaching.
 5. You did many experiments during this semester. Write one of the experiments that you would like to conduct the partially open inquiry, like the Newton's law experiments. Which experiment is more suitable for the partially open inquiry, and describe the reason.

Research Question (Problem)

- ✓ Do students experiment with open inquiry even after they conduct an experiment on the same topic following a manual?
- ✓ How do the students' specific practices appear and what do they mean in the open laboratory activity?
- ✓ What is the students' learning from the open laboratory activity, and do they recognize the value of openness?



Students' Practices for Better Experiment

What students wanted to solve

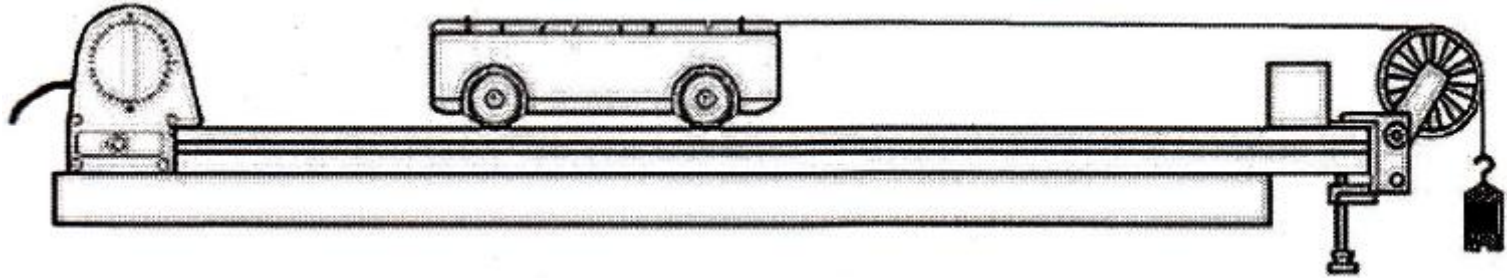

- ✓ They really want to Improve Accuracy (reduce error rate)
 - There was about a 10% error rate!
 - However, students could not accept this level of error, as they have been accustomed to using Newton's Second Law almost instinctively when solving dynamics problems.

- ✓ They thought there are three main reason for the error
 - Friction of the cart (variable friction depending on the weight, speed, and location of the cart)
 - Friction of pulley (friction between thread and pulley, rotational inertia)
 - Sway of a weight (decrease of the pulling force)

What students wanted to solve

Cart



Get rid of the cart (Make Atwood machine)

Precise control of friction acting on cart

Pulley



Find the relationship between friction and tension

Do not use pulley (Using a cylinder type metal bar)

Weight



Measure the influence of the weight

Minimized sway of weight

New



Centripetal force experiment

A system in which mass changes continuously

Students' Practices (about cart)

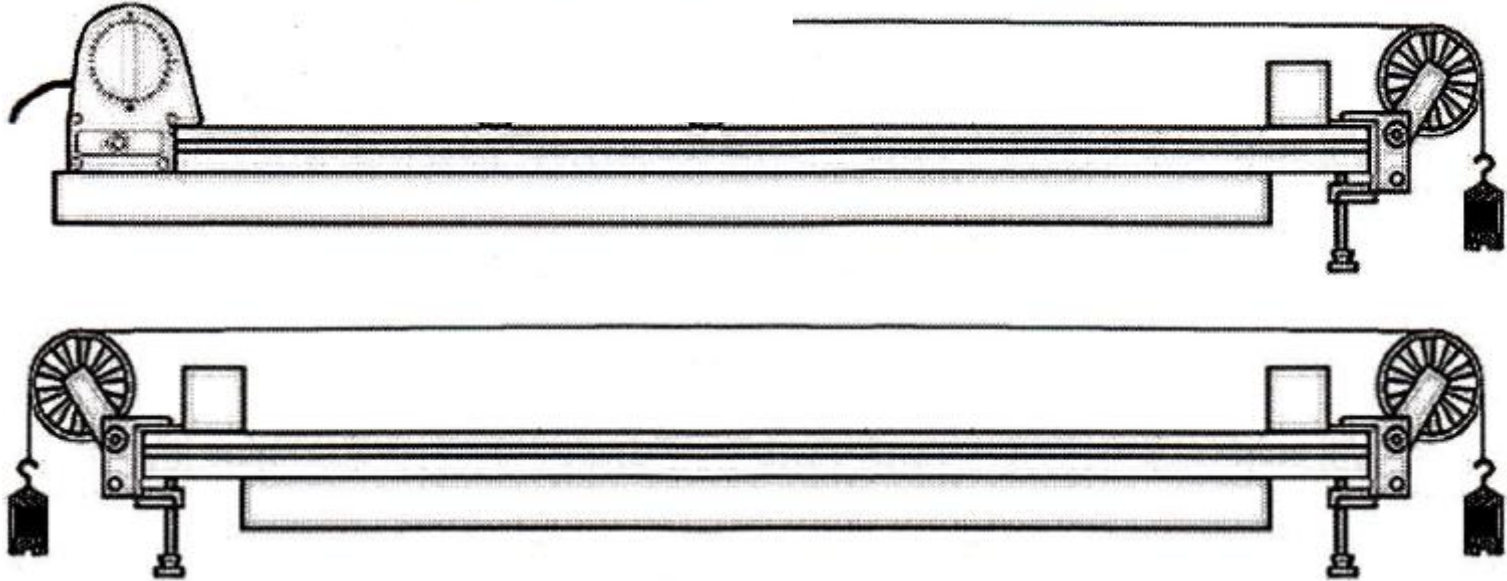

- ✓ *The process of considering friction has been a pain. The impact of friction on the experiment turned out to be more substantial and complex than anticipated. I realized how friction played a significant role in our lives.*

Remove the Cart

Make Atwood Machine

Students' Practices (about cart)

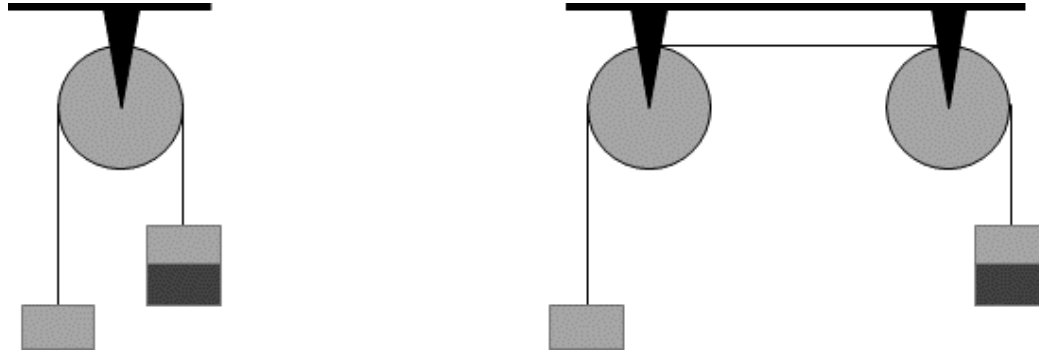

- ✓ The students had no prior experience setting up an Atwood machine experimentally.
- ✓ The biggest problem students faced was that object acceleration was too high.
- ✓ To solve these problems, students designed various kinds of Atwood machines.
- ✓ The students set up an equal mass of weight on both sides of the pulley at first, and then they added a weight to the experiment. By doing that, they could make a big mass system with small acceleration.
- ✓ Students who made two pulley systems considered the sway of weight and collision between weights.

Students' Practices (about cart)

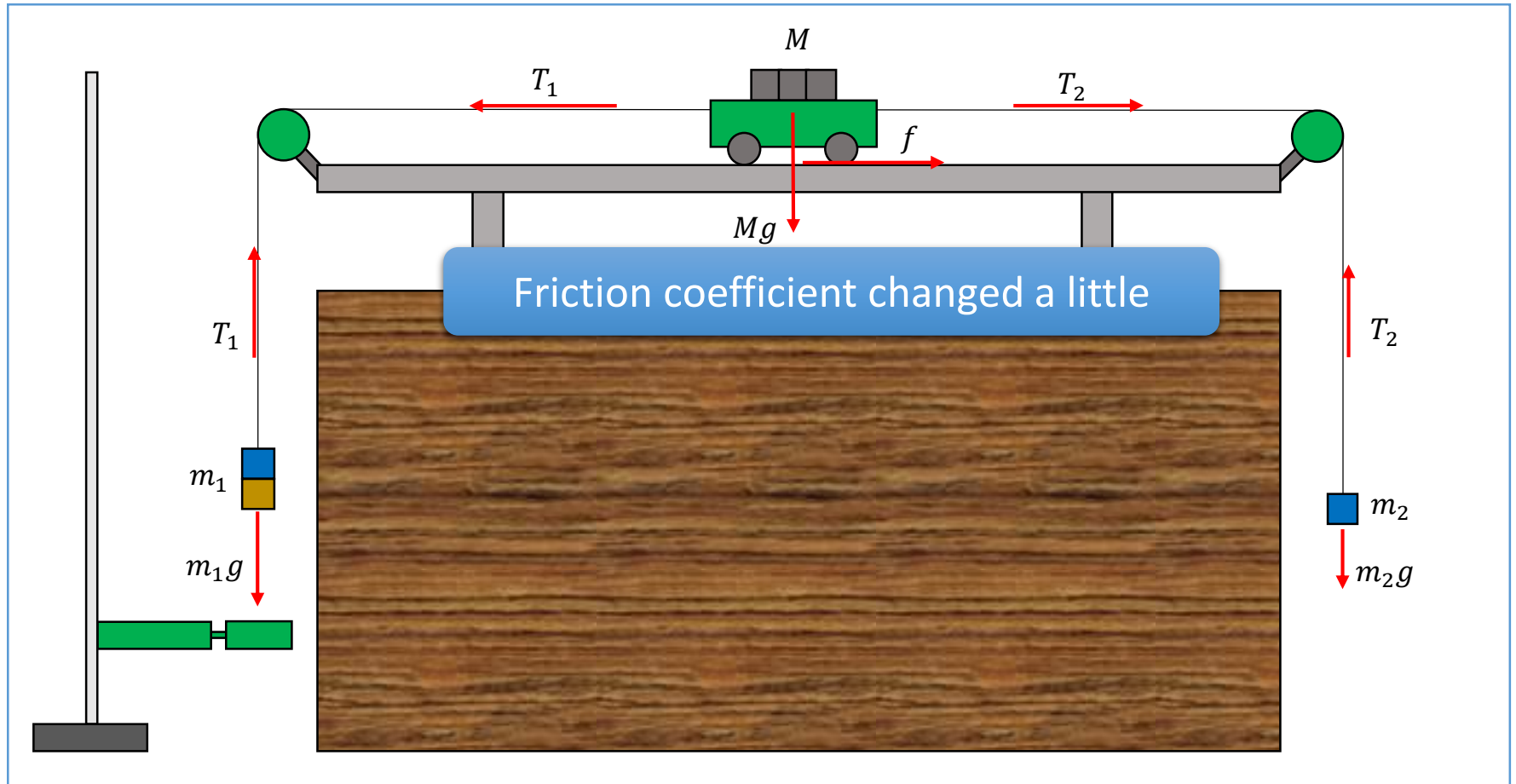

Add the weights on both sides



Keep the mass of the cart constant
(The mass of the system changes)

Students' Responses (about cart)

Even though this experiment was carried out using a cart, the accuracy and precision were improved. Besides, it was interesting to quantitatively analyze the causes of various errors that may occur in the experiment. In particular, the method for keeping friction of the cart constant was interesting. The idea that the mass of the cart could be constant while the weight of the same mass could be attached to both sides of the cart in order to change the mass of the system was great.

Students' Practices (about cart)

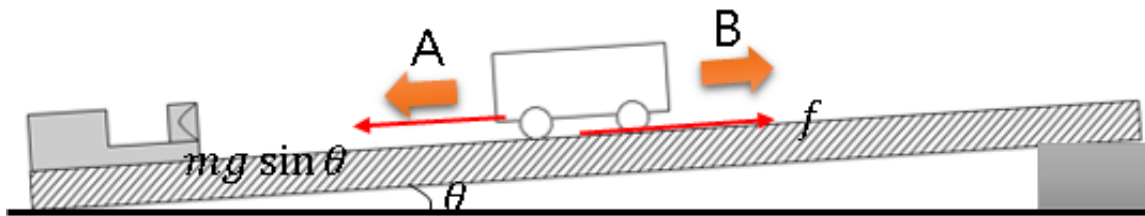

$$A: a_1 = \frac{f}{m} - g \sin \theta$$

$$B: a_2 = \frac{f}{m} + g \sin \theta$$

$$f = (a_1 + a_2) \frac{m}{2}$$

$$\theta = \sin^{-1} \left(\frac{a_2 - a_1}{2g} \right)$$

- ✓ Although we prepared levelling instruments, the students wanted to control the level more precisely.
- ✓ In this experiment, just missing the level by 0.1 degrees could make about a 10% error rate.
- ✓ To solve the problem, the students investigated the cart's movement on both sides.
- ✓ According to these equations, students could determine the friction and the tilted angle at the same time just by measuring the two accelerations when the cart moves upward and downward.

Students' Responses (about cart)

When we tried to level the rail, a slight difference in angle cause errors. Thus, this group tried to find the friction and the horizontal angle at the same time through investigating the cart's movements on both sides. I think this idea is very creative and impressive.

Students' Practices (about pulley)

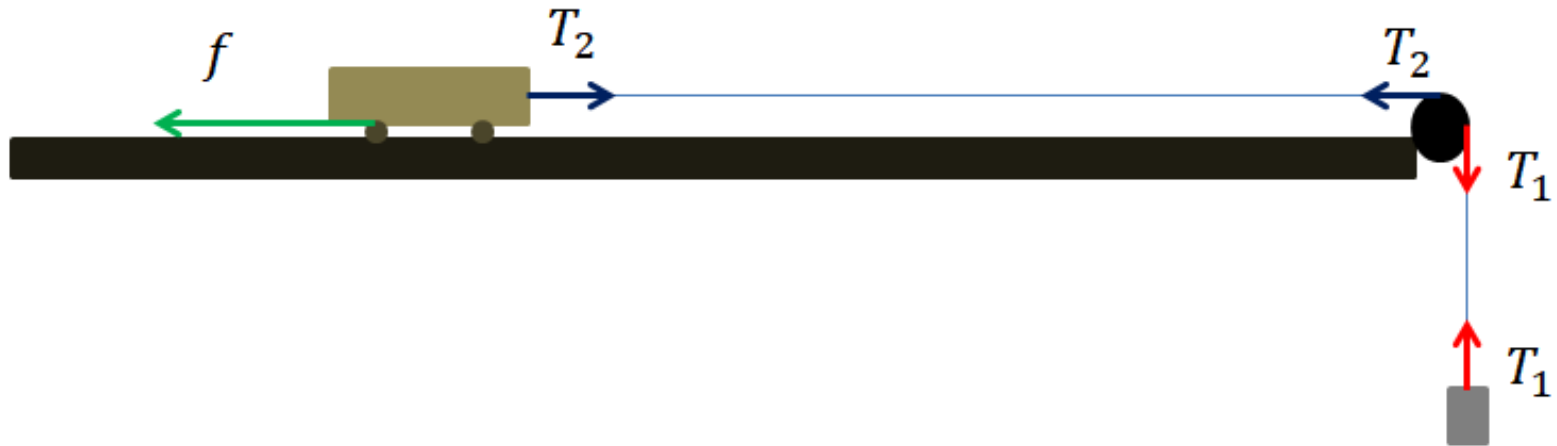

- ✓ When the students solved this kind of problem, they usually considered the two tensions acting on the pulley to be equal.
- ✓ However, this group of students doubted this assumption and wanted to know the relationship between friction and the two different tensions.
- ✓ Some students derived Capstan equation $T(\theta) = Ce^{-\mu_k\theta}$ which can show the relationship between tension and friction.
- ✓ And then, they measured the slip of the thread on the pulley using video analysis to determine the coefficient of kinetic friction between thread and pulley.

Students' Responses (about pulley)

Our group also thought that the friction between the thread and the pulley is a significant cause of error, but I didn't think it could be calculated. However, this group of students calculated the friction of the entire thread by integrating from a small angle and derived the Capstan equation. It was an interesting presentation because I never thought that problem could be solved.

Students' Practices (about weight)

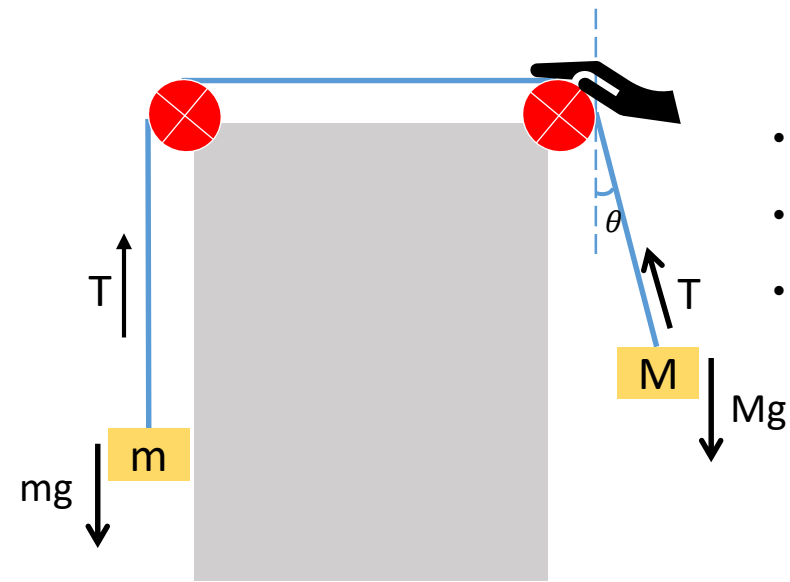

- $\theta(t) = 1.570e^{-1.758t} \sin(6.578t + 2.801) + 0.03596$ ($1.6 \leq t \leq 2.7$)
- $\theta(t) = 2.459e^{-0.6456t} \sin(4.177t + 4.106) + 0.1115$ ($2.24 \leq t \leq 3.81$)
- $\theta(t) = 0.6642e^{0.3178t} \sin(4.936t + 4.473) - 0.2232$ ($0 \leq t \leq 0.667$)

- ✓ Students thought that if the weight moves horizontally, it could reduce pulling force acting on the cart.
- ✓ Although it was not easy to determine the movement of the weights, students investigated the movement of the weights and found the effect of this movement using video analysis.
- ✓ The figure shows an experimental setting which generated a sway of weight, and they found the damping equation of the weight experimentally.

Students' Responses (about weight)

I thought that the biggest error factor in this experiment was friction acting on the cart, but the sway of the weight could also act as an error factor. This group analyzed the sway of the weight with a tracker and modeled the sway of the weight and the factors caused by the sway of the weight quantitatively, and they were able to produce an exact analysis. As a result, the error factor from this was found to be very small, but I thought it also had a good result.

Students' Practices (about weight)

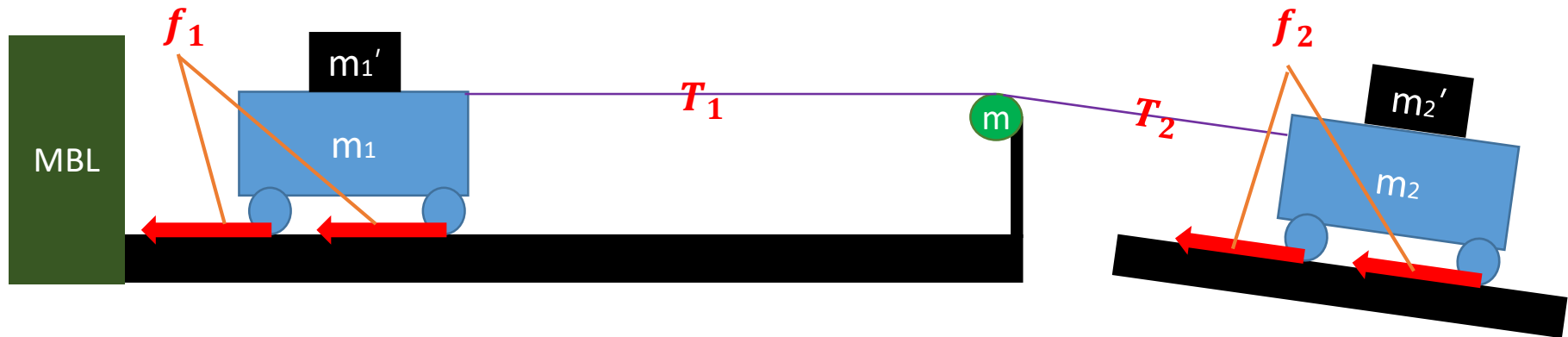

- ✓ Some students wanted to minimize sway of weight using another cart on an incline instead of the weight.
- ✓ In this experimental setting, the cart on an incline performed the role of the weight pulling the original cart.
- ✓ Their attempts to avoid the effect were distinguished from the previous ones because the previous groups tried to determine the effects of the sway of the weights.

Students' Responses (about weight)

I wondered why they changed the experimental setting and used two carts. However, I thought it was a good idea when I found out that the reason was to rule out the error caused by the sway of the weight. Their presentation was impressive because they dealt with an error factor that was not considered in our group's experiments.

Students' Practices (New attempt)

How our experiment did not use Newton's 2nd law.

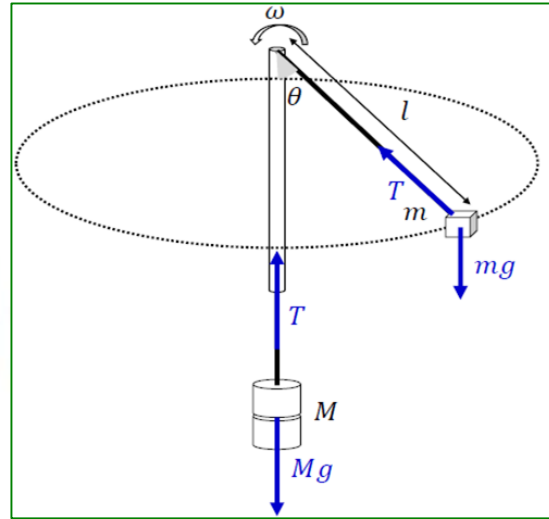
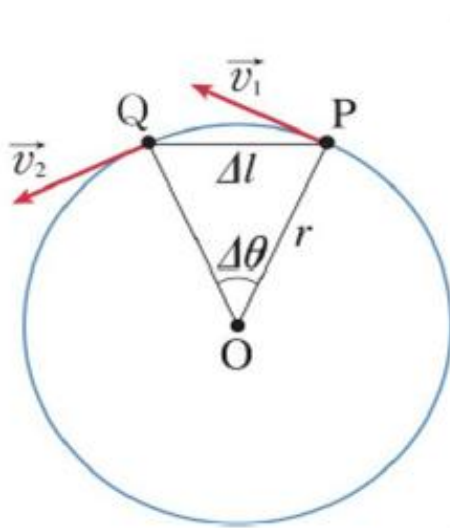

$$\Delta v = 2v \sin\left(\frac{\Delta\theta}{2}\right) \cong v\Delta\theta$$

$$\Delta\theta = \frac{\Delta l}{r}$$

$$v\Delta\theta = v \frac{\Delta l}{r}$$

$$a_R = \lim_{\Delta t \rightarrow 0} \frac{\Delta v}{\Delta t} = \lim_{\Delta t \rightarrow 0} \frac{v \Delta l}{r \Delta t} = \frac{v^2}{r}$$

- ✓ During the experiment to confirm Newton's second law, these students were reluctant to apply Newton's second law in the experimental process.
- ✓ As presented in the figure, the students explained how their experiment did not use Newton's second law.
- ✓ Centripetal acceleration was estimated by tangential velocity, and centripetal force was estimated by the gravity of the weights. From this experiment, they tried to show the relationship between force and acceleration.

Students' Responses (New attempt)

Although the error was a bit large, I thought it was important to try new experimental methods. In fact, if we do science or mathematics, no one will tell us a specific way to conduct experiments or research. Their presentations were the most impressive because I thought it was very important to think differently from the existing methods.

Students' Practices (New attempt)

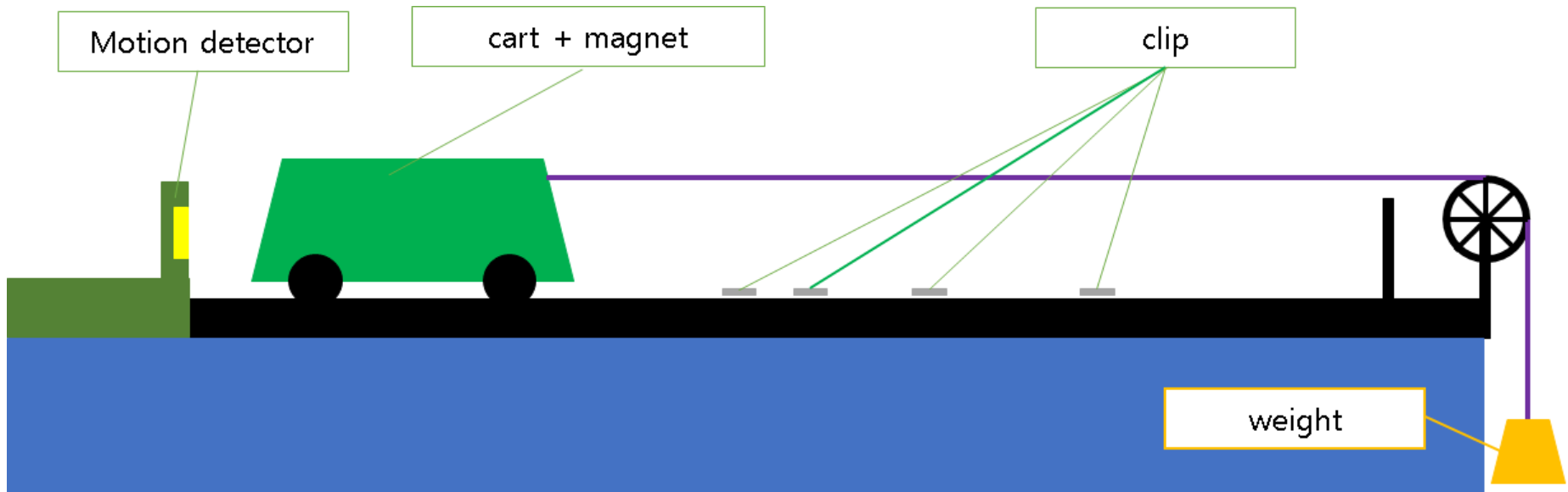

- ✓ These students considered Newton's first definition of the second law for their experiment.
- ✓ They focused on the fact that Newton defined the second law as $f=dp/dt$, not $f=ma$.
- ✓ They wanted to see if Newton's second law applied even when the mass of the object changes.
- ✓ To do so, they put clips on the road where the cart moved, and they placed a magnet on the cart to pull the clips when the cart passed over them.

Students' Responses (New attempt)

*This presentation was **the most impressive in my class**. They used magnets and calculated the change in momentum when the clip was attached. **They did an experiment that best fit Newton's first definition of the second law of motion.***



Students' thinking and learning for the activity in this study

What students think they have learned

Categories	Contents	Number of Responses
Law and reality	<ul style="list-style-type: none">• Recognition of the various ways to verify a law• Complexity of real phenomena• Difference between law and reality	39 (31.0%)
Understanding experiment	<ul style="list-style-type: none">• Characteristics of an error• Importance of experiment design and specific experiment process• Meaning of experiment process	41 (32.5%)
Reflective thinking	<ul style="list-style-type: none">• A doubtful attitude• Real meaning of the Newton's second law• A cooperative attitude	46 (36.5%)

Law and reality

It was also surprising that various experiments were designed from just one theme. Various methods were used, ranging from differences in experimental procedures to differences in experimental devices such as MBL and trackers. Students must consider which method was the most efficient and accurate when designing an experiment.

The law of $F=ma$ itself is very simple, and the basic principle to verify the law is also simple. Just apply a force to some object and measure the acceleration. However, this seemingly simple experiment had many more error factors than I thought at first, and many things needed to be considered to reduce these errors.

The experiment was not so simple. It is important to consider how the individual experimenter designed the experiment and how error is corrected because these factors greatly affect the experiment's ability to prove the law. I realized the fact that establishing a law and proving it experimentally are very different activities, and the two activities require different kinds of knowledge and experience.

Understanding science experiment

I learned the necessity and importance of quantitatively analyzing the errors in experiments. Previously, I ended up roughly identifying what was the cause of an error. This time, I could quantitatively analyze the error to clarify the ratio of the error among the total errors. This made it possible to determine the contribution of the error and to identify the possibilities for reducing error.

The biggest thing I noticed was that I could do this experiment in a wide variety of ways, even if I was seeking to identify a simple law. Therefore, when we went through the experiment, we had to choose the most accurate and valid method out of the many possible methods, and this was a very difficult process. In other words, following a guided written process is not a real experiment, but design through much consideration and effort is the beginning of a true experiment.

I thought about what a good experiment is. I usually think that a good experiment means an experiment with less error rate. Surely it is an important element of good experiments, but it is not all we should be looking for in good experiments. For example, the second group's experimental results were not good, but I think their results were still meaningful. This is because the process of devising, designing, and conducting their own experiment has enough value on its own. In a good experiment, the accuracy of the results is of course important, but I found that the process must also be considered.

Reflective thinking

Three weeks of inquiry about $F=ma$ led me to question whether the $F=ma$ experiment really worked. This activity gave me time to think about how we can prove the law effectively... After three weeks of the experiments, I was able to learn how to perform experiments from design to conclusion. In the future, I will judge whether something is true through both my thoughts and my experiments.

Newton's law of motion has always been expressed as a law. We can treat it as a law because it was obtained through observation. However, these laws of motion are at the core of classical mechanics theory, and Newton's laws of motion should be treated as axioms that cannot be seen directly as proved by experiments. We can only test ideas derived from Newton's law. From this perspective, I think Newton's laws of motion should be viewed as principles.

When experimenting, I felt the need for consideration and a receptive attitude. The experiment went smoothly when we actively embraced the opinions of others and helped each other. I learned that this is a desirable attitude when experimenting.

What we think they have learned

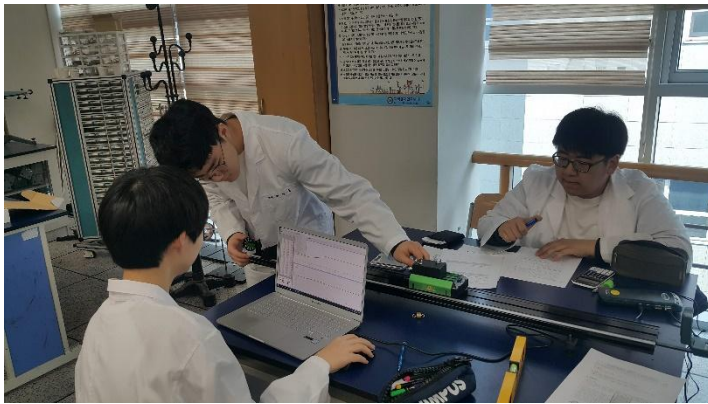
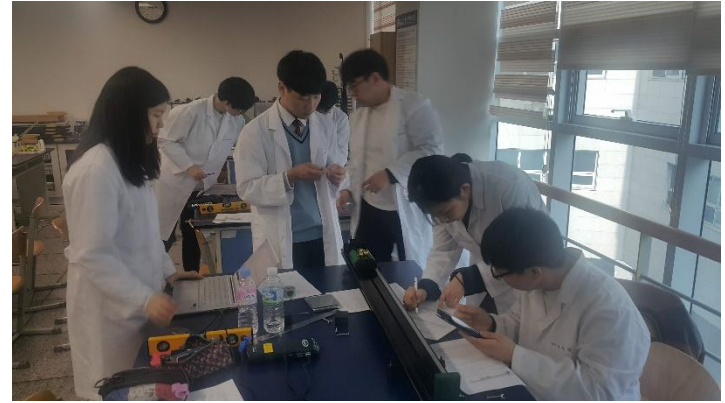
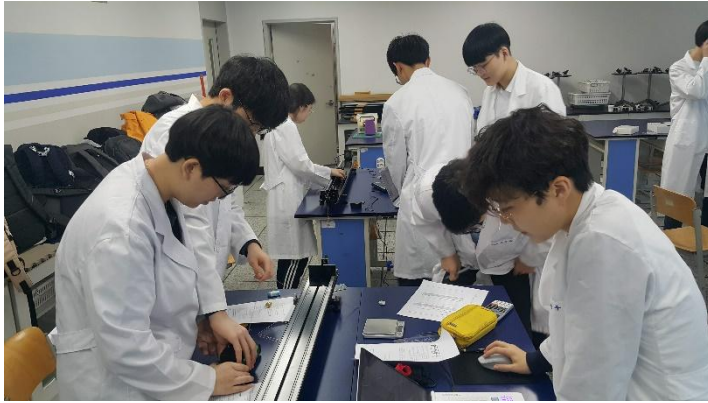

- ✓ Above all, it was evident that students were **more engaged** in the experiment and seemed to **enjoy** the process itself compared to other cookbook-style experiments.

Conclusion

- ✓ The students tried various experimental designs, and they demonstrated diverse creative practices after deep consideration about the true meaning of Newton's second law experiments.
- ✓ Nearly all students responded positively to the experiments in this study, and they insisted that other experiments should be conducted in this way.
- ✓ Students also seemed to realize that there are various methods to prove a law, and they recognized the complexity of the actual phenomenon.
- ✓ Students' learning in this study was similar what students learn from fully open inquiry. (considering free experimental design, decide specific experiment method, distinction between key and marginal factors for experiment, etc.)
- ✓ The activity in this study could be one steppingstone to adapt open inquiry in the classroom. If it is difficult to conduct an open inquiry fully in school, partially open inquiry introduced in this study could be a good alternative.



Thank you for your listening!